

# KOMATSU®

**NET HORSEPOWER**  
71 kW **95 HP** @ 2200 rpm

**OPERATING WEIGHT**  
D39EX: 8520 kg **18,780 lb**  
D39PX: 8900 kg **19,620 lb**

## D39EX-21 D39PX-21

**D**  
**39**

CRAWLER DOZER



Photos may include optional equipment.

# WALK-AROUND

## ***The Komatsu SAA4D102E-2 turbocharged diesel engine***

provides an output of 71 kW **95 HP**, with excellent productivity. This engine is Tier 2 EPA, EU, and Japan emissions certified.

***Gull-wing*** engine side doors for easy servicing.

## ***Palm Command Control System (PCCS)***

Left hand controls all tractor motion. Right hand controls all blade movements.

## ***Front Grill***

Heavy-duty, punched steel.

## ***Radiator Nose***

Sound deflection style for reduced ambient noise.

***New*** design, larger diameter shimmed center ball.

High capacity  
***Power Angle Tilt dozer blade***  
combines the highest power in its class with outstanding productivity.



## ***Komatsu Hydrostatic Transmission (KomStat II)***

offers palm control of speed (3 forward and 3 reverse), turning directional changes, and power steering with PPC valve control.

***Electronic Monitoring System***

provides critical information about the machine.

***Optional quadrangle design, low noise pressurized ROPS cab***

One-piece front glass window offers exceptional front, side, and rear visibility.

**NET HORSEPOWER**

71 kW **95 HP** @ 2200 rpm

**OPERATING WEIGHT**

D39EX: 8520 kg **18,780 lb**

D39PX: 8900 kg **19,620 lb**

**BLADE CAPACITY****PAT DOZER**

D39EX: 2.22 m<sup>3</sup> **2.87 yd<sup>3</sup>**

D39PX: 2.32 m<sup>3</sup> **3.00 yd<sup>3</sup>**

***Side compartment doors***

for easy access to battery and hydraulics.

***Final drives and travel motors***

are completely protected within the track shoe width.

***Bolt-on sprocket segments***

for ease of maintenance.

***Modular power train*** for increased serviceability and durability.

Photos may include optional equipment.

***Intermediate speed selection*** enables setting of optimum travel speed to job conditions, improving grading accuracy.

## ENGINE AND HYDROSTATIC TRANSMISSION

### Komatsu SAA4D102E-2 Turbocharged and Aftercooled Diesel Engine

#### Powerful Engine

A powerful SAA4D102E-2 turbocharged and air-to-air aftercooled diesel engine provides a massive output of 71 kW **95 HP**. This engine is Tier 2 EPA, EU, and Japan emissions certified, without sacrificing power or machine productivity. The engine power is transmitted via a high-efficiency Komstat II Hydrostatic Transmission to the final drives.

### KomStat II Hydrostatic Transmission (HST)

#### HST Control

The D39 is equipped with Komatsu's exclusive Komstat II Hydrostatic Transmission (HST) that allows for variable speed selection or intermediate speed selection. The D39's HST consists of dual-path closed-circuits with two variable displacement piston pumps and two 3-speed variable displacement travel motors.

#### Palm Command Control System (PCCS)

Palm Command Control System (PCCS) joystick controls all directional movements. Pushing the joystick forward results in forward machine travel, while pulling it rearward reverses the machine. Simply tilt the joystick to the left to make a left turn, and to the right for a right turn. Tilting the joystick fully to the left or right results in counter-rotation. Hydrostatic steering eliminates steering clutches and brakes, providing smooth powerful turns. Fully electronic control enables smooth shockless control.



Left Hand

#### Steering Functions



Forward and reverse



Right and left steering plus counter-rotation



Speed up and speed down control

#### Superb Steering Accuracy

The Komstat II steering system offers smooth steering performance even in gradual turns, permitting the D39 to approach dozing objects accurately in corner grading and side wall operations.

#### Variable Speed Selection

When the variable speed selection is engaged, a gradual speed increase is available. Travel speed is adjustable through a 20 increment LED, by utilizing the shift button on the PCCS control to increase or decrease speed gradually. While depressing and holding the shift button on the PCCS control, speed will automatically increase or decrease as activated. Selection of either intermediate or variable speed allows the KomStat II dozers to achieve maximum efficiency during fine or rough grading operations with optimum travel speed to match job conditions.

#### Intermediate Speed Selection

Enables the setting of predetermined ranges. This means the operator can select 1st, 2nd, or 3rd range to correspond with existing job site conditions.

#### Counter-rotation

Allows the operator to correctly position the dozer when side loading the blade or working in a narrow environment.

#### HST Dynamic Brakes

The D39 uses HST dynamic braking to ensure smooth operation. Parking brake is wet, multiple-disc type with a unique drag-prevention control to keep hydraulic oil clean.

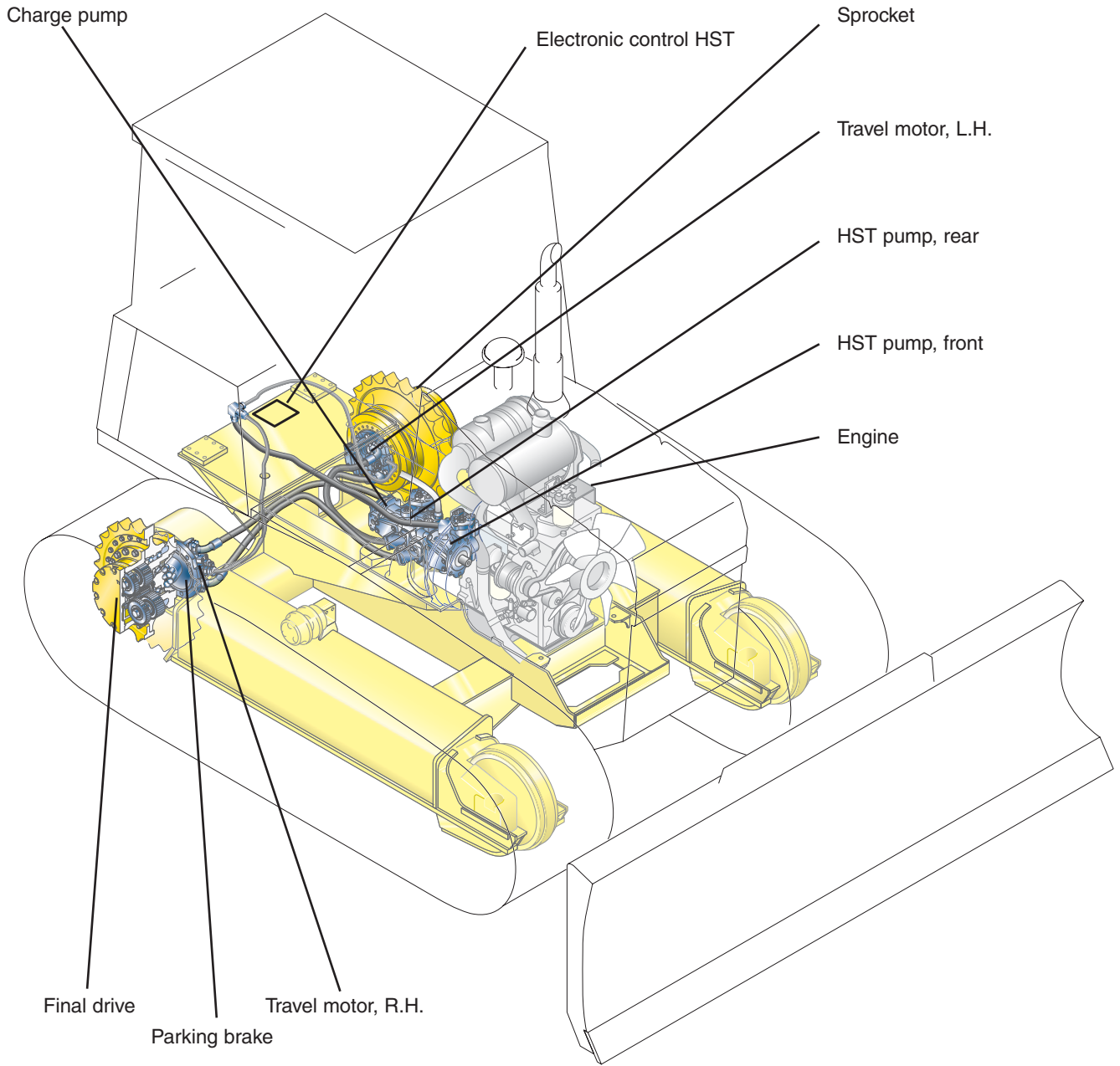

## EXCELLENT GRADING ABILITY

### Outstanding Stability

The large ground contact area created by the long tracks and wide track gauges combines with a low center of gravity to make a stable and well-balanced machine that can perform precise grading work on rough or inclined terrain.

### Exceptional Blade Visibility

The slim engine hood and well-located operator seat provide excellent visibility to the blade. This clear blade visibility greatly increases grading efficiency and reduces operator guesswork. Finish grading and rough grading can be performed easily, drastically reducing cycle times.

### Easy-to-Operate, 3-Axis PPC Operated Implement Control Joystick

Newly developed 3-axis PPC valve and ergonomically designed joystick provide light operating effort and excellent blade response.

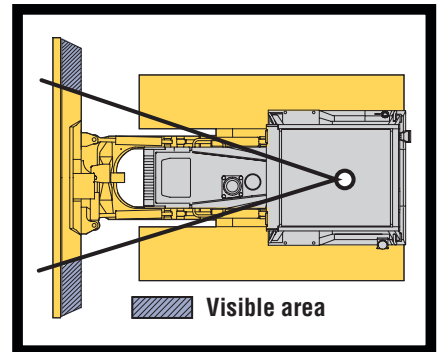

### CLSS Hydraulic System

With the hydraulic Closed-center Load Sensing System (CLSS), blade lever stroke is directly proportional to blade speed, regardless of the load and travel speed. This results in superb, fine controllability.

#### Benefits of CLSS

- More precise and responsive operation due to the pressure compensation valve
- Reduced fuel consumption by discharging only the required amount of oil from the pump
- Compound operations such as blade raise, tilt, and angle are easy due to CLSS parallel circuit with pressure compensation valve

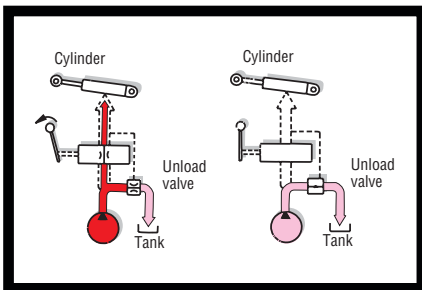

### Blade Geometry

The Komatsu blade geometry is designed to maximize the blade curvature. The large blade radius allows the rolling-up performance of the material to be maximized by utilizing the entire blade. This provides excellent productivity while maintaining the superb grading capabilities of the KomStat II.



Right Hand

### Blade Functions

↑ ↓  
Lifting and lowering

← →  
Tilting

↻  
Left and right angling

# OPERATOR'S COMPARTMENT

## Low-Noise Design

For smoother riding comfort, power train components and hydraulic control valves are mounted to the frame with rubber pads to soften vibration and shut out noise. Since the D39 employs joysticks, the walk-through operator compartment is uncluttered for smooth entry and exit. A suspension seat with backrest and retractable seat belt is standard equipment.

## Quadrangle Pressurized Cab (Optional)

This is another added comfort feature. Air filters and a higher internal air pressure combine to reduce external dust from entering the cab. In addition, the cab's design, with a large one-piece front glass window, provides excellent front, side and rear visibility. Rubber isomount cab suspension mounts soften shocks for operator comfort and extend component life. Cab features largest volume in its class, low noise 76 dB(A), and air vents arranged for optimum ventilation.

## Fully Adjustable Suspension Seat With Retractable Seat Belt



Photos may include optional equipment.



## Height Adjustable Armrests

Height adjustable armrests and conveniently located fuel control lever provide comfortable operation and increase leg space.



## ROPS Cab



## MAINTENANCE FEATURES

### Electronic Monitoring System

An electronic monitoring system provides critical information about the machine.

All meters and gauges are controlled by a microcomputer, which provides a wide indication range for an easier, more precise reading.



- Charge Lamp
- Engine Oil Pressure Caution Lamp
- Engine Water Temperature Gauge
- Fuel Gauge
- HST Speed Range Indicator
- HST Oil Temperature Gauge
- HST Charge Filter Caution Lamp
- Intake Air Heater Lamp
- Maintenance Monitor Display
- Reverse Speed Gauge
- Service Meter



#### Gull-Wing Engine Side Covers

*With a gas-spring cylinder that opens 140°, the engine and the auxiliary components can be checked easily.*



*Daily maintenance items are centralized on left side of engine.*



#### Reservoir

*A radiator coolant reservoir makes it easier to check the coolant level and eliminates frequent refilling.*



#### Improved Towing Hitch

*The hitch extends past the track rear to allow maximum angle when towing.*

#### Tow Valve

*Tow valve opens brake circuit manually to tow tractor when engine is stopped.*

#### Long Engine Oil Replacement Interval

*Engine oil replacement interval is extended to 500 hours using a high performance engine oil filter.*



# UNDERCARRIAGE AND FRAME

## Frame

### Durable and Reliable Main Frame

The main frame is designed by the same advanced Computer Aided Engineering (CAE) technology used on the D575A (the largest bulldozer in the world). This main frame structural feature is a main frame and track frame combined with connecting bars by weldments, providing the ideal stiffness required in a small size crawler dozer.



### Protected Travel Motors and Final Drives

Travel motors and final drives are mounted inside the track shoe for protection from rocks and stumps, and for improved durability.

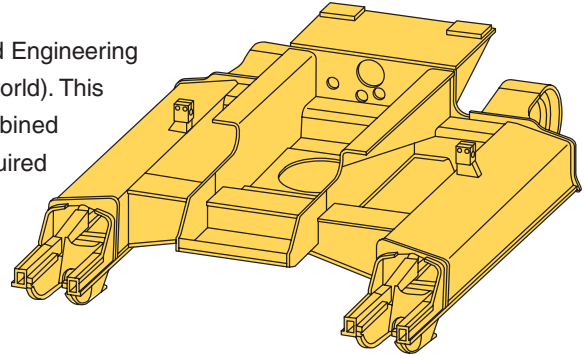

## Undercarriage

### Durable and Reliable Undercarriage

Life of undercarriage and reliability are greatly extended by use of large size links, pins, bushings, and unique dust seals. An optional Abrasive Resistant ("AR") Link is available on the D39EX/PX-21. This allows for improved undercarriage life in low impact/high abrasion applications.



# D39EX/PX-21 CRAWLER DOZER

## SPECIFICATIONS



### ENGINE

Model . . . . . Komatsu SAA4D102E-2  
 Type . . . . . Water-cooled, 4-cycle, emissionized  
 Aspiration . . . . . Turbocharged and air-to-air aftercooled  
 Number of cylinders . . . . . 4  
 Bore . . . . . 102 mm **4.02"**  
 Stroke . . . . . 120 mm **4.72"**  
 Piston displacement . . . . . 3.9 ltr **240 in<sup>3</sup>**  
 Net flywheel horsepower\*:

SAE J1349 . . . . . 71 kW **95 HP** @ 2200 rpm  
 DIN 6270 . . . . . 71 kW **96 PS** @ 2200 rpm  
 Net maximum torque . . . . . 431 N•m 44 kg•m **318 lb•ft** @ 1300 rpm  
 Governor . . . . . All-speed, mechanical  
 Filter . . . . . Full-flow

Direct injection fuel system. All-speed mechanical governor.  
 Forced lubrication driven by gear pump. Full-flow for lube purification. Dry-type air cleaner with automatic dust evacuator and dust indicator. 5.5 kW/24 V electrical starter motor.  
 35 A/24 V alternator. 60 Ah/2 x 12 V batteries.

\* Net flywheel horsepower output for standard engine (SAE J1349) including air cleaner, alternator (not charging), water pump, lubricating oil pump, fuel pump, muffler, and fan.



### KOMSTAT II HYDROSTATIC TRANSMISSION

Dual-path, hydrostatic transmission provides infinite speed change up to 8.5 km/h **5.3 mph**. The variable capacity travel motors allow the operator to select the optimum speed to match specific jobs. Gearshift lock lever and neutral start switch.

Travel speed (quick shift mode)	Forward	Reverse
1st	0–3.4 km/h <b>0–2.1 mph</b>	0–4.1 km/h <b>0–2.5 mph</b>
2nd	0–5.6 km/h <b>0–3.5 mph</b>	0–6.5 km/h <b>0–4.0 mph</b>
3rd	0–8.5 km/h <b>0–5.3 mph</b>	0–8.5 km/h <b>0–5.3 mph</b>

Travel speed (variable mode)	Forward	Reverse
	0.8 - 8.5 km/h <b>0.5–5.3 mph</b>	0.8–8.5 km/h <b>0.5–5.3 mph</b>

Maximum drawbar pull:

D39EX-21 . . . . . 135 kN 13800 kgf **30,430 lb**  
 D39PX-21 . . . . . 135 kN 13800 kgf **30,430 lb**



### STEERING SYSTEM

Palm Command Control System (PCCS) joystick control for all directional movements. Pushing the joystick forward results in forward machine travel, while pulling it rearward reverses the machine. Simply tilt the joystick to the left to make a left turn. Tilt it to the right for a right turn. Tilting the joystick fully to the left or right activates counter-rotation. Hydrostatic steering eliminates steering clutches and brakes, providing smooth powerful turns. Fully electronic control enables smooth, shockless control. The PCCS utilizes shift buttons to increase and decrease speed.

Minimum turning radius:

D39EX-21 . . . . . 2.61 m **8'7"**  
 D39PX-21 . . . . . 2.80 m **9'2"**

(As measured by track marks on the ground)



### FINAL DRIVE

Two-stage planetary gear integrated into axial piston travel motors. Compact in-shoe mount reduces risk of damage by debris. Bolt-on sprockets for easy replacement.



### UNDERCARRIAGE

Suspension . . . . . Rigid type  
 Track roller frame . . . . . Box section, high-tensile-strength steel structure  
 Rollers and idlers . . . . . Lubricated idlers/carrier rollers, track rollers are sealed with floating seals  
 Double flange rollers . . . . . 3 per side  
 Lubricated tracks:

Unique dust seals for reducing entry of foreign abrasive into pin-to-bushing clearance for extended service. Track tension easily adjusted with grease gun.

	D39EX-21 KomStat II	D39PX-21 KomStat II
Number of carrier rollers (each side)	1	1
Number of track rollers (each side)	6	6
Number of shoes (each side)	39	39
Grouser height	53.0 mm <b>2.1"</b>	53.0 mm <b>2.1"</b>
Shoe width (standard)	460 mm <b>18"</b>	635 mm <b>25"</b>
Ground contact area	21710 cm <sup>2</sup> <b>3,365 in<sup>2</sup></b>	29970 cm <sup>2</sup> <b>4,645 in<sup>2</sup></b>
Ground pressure	38.2 kPa 0.39 kgf/cm <sup>2</sup> <b>5.55 psi</b>	29.4 kPa 0.30 kgf/cm <sup>2</sup> <b>4.27 psi</b>
Track gauge	1650 mm <b>5'5"</b>	1790 mm <b>5'10"</b>
Length of track on ground	2360 mm <b>7'9"</b>	2360 mm <b>7'9"</b>



### COOLANT AND LUBRICANT CAPACITY (REFILL)

Coolant . . . . . 32 ltr **8.5 U.S. gal**  
 Fuel tank . . . . . 165 ltr **43.6 U.S. gal**  
 Engine oil . . . . . 12.5 ltr **3.3 U.S. gal**  
 Hydraulic tank . . . . . 47 ltr **12.4 U.S. gal**  
 Final drive (each side) . . . . . 3.5 ltr **0.9 U.S. gal**



### OPERATING WEIGHT (APPROXIMATE)

Tractor weight:

Including rated capacity of lubricant, coolant, full fuel tank, operator, and standard equipment.

D39EX-21 . . . . . 6950 kg **15,320 lb**  
 D39PX-21 . . . . . 7230 kg **15,940 lb**

Operating weight:

Including power angle tilt dozer, ROPS canopy, operator, standard equipment, rated capacity of lubricant, coolant, and full fuel tank.

D39EX-21 . . . . . 8520 kg **18,780 lb**  
 D39PX-21 . . . . . 8900 kg **19,620 lb**



**DIMENSIONS (POWER ANGLE TILT DOZER)**

	D39EX-21		D39PX-21	
A	1255 mm	4'1"	1255 mm	4'1"
B	2740 mm	9'0"	3330 mm	10'11"
B*	N/A	N/A	2980 mm	9'10"
C	395 mm	1'4"	480 mm	1'7"
D	2720 mm	8'11"	2720 mm	8'11"
E	890 mm	2'11"	890 mm	2'11"
F	440 mm	1'5"	440 mm	1'5"
G	2360 mm	7'9"	2360 mm	7'9"
H	3780 mm	12'5"	3780 mm	12'5"
I	4200 mm	13'9"	4200 mm	13'9"
J	1605 mm	5'3"	1605 mm	5'3"
K	1965 mm	6'5"	1965 mm	6'5"
L	2770 mm	9'1"	2770 mm	9'1"
M	53 mm	2.1"	53 mm	2.1"
N	1650 mm	5'5"	1790 mm	5'10"
O	460 mm	1'8"	635 mm	2'5"
P	2110 mm	6'11"	2425 mm	7'11"
Q	372 mm	1'3"	448 mm	1'6"
R	2510 mm	8'3"	3040 mm	9'11"
R*	N/A	N/A	2800 mm	9'2"

Ground clearance . . . . . 384 mm 15.1"

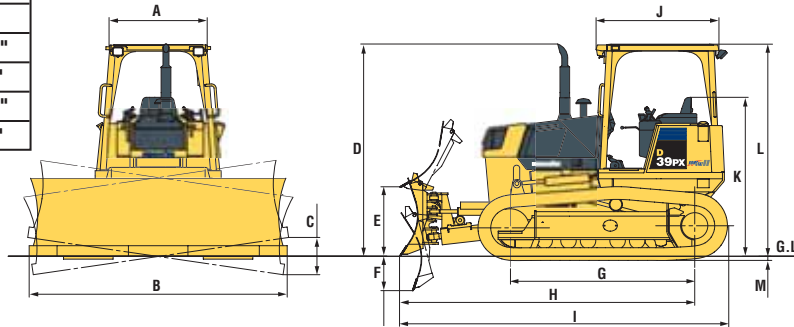
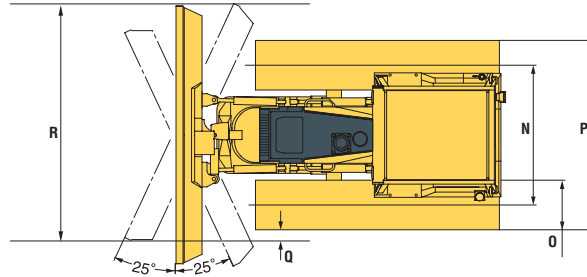

\* Narrow Blade (available on D39PX Model only)



**HYDRAULIC SYSTEM**

Closed-center Load Sensing System (CLSS) designed for precise and responsive control and for efficient simultaneous operation.

**Hydraulic control unit:**

All-spool control valves externally mounted beside the hydraulic tank. Gear-type hydraulic pump with capacity (discharge flow) of 93 ltr/min **24.6 U.S. gal/min** at rated engine rpm.

Relief valve setting . . . . . 20.6 MPa 210 kg/cm<sup>2</sup> **2,990 psi**

**Hydraulic cylinders** . . . . . Double-acting, piston type

	Number of Cylinders	Bore
Blade lift	2	90 mm <b>3.54"</b>
Blade tilt	1	90 mm <b>3.54"</b>
Blade angle	2	85 mm <b>3.35"</b>

**Hydraulic oil capacity (refilling):**

Power angle tilt dozer . . . . . 47.0 ltr **12.4 U.S. gal**

**Control valves:**

3-spool control valve for power angle tilt dozer.

Positions:

- Blade lift . . . . . Raise, hold, lower, and float
- Blade tilt . . . . . Right, hold, and left
- Blade angle . . . . . Right, hold, and left

Additional control valve required for ripper.

Positions:

- Ripper lift . . . . . Raise, hold, and lower



**DOZER EQUIPMENT**

Blade	Overall Length With Dozer	Blade Capacity (SAE)	Blade Width x Height	Maximum Lift Above Ground	Maximum Drop Below Ground	Maximum Tilt Adjustment	Blade Angle
D39EX -21 Power Angle Tilt Dozer	4200 mm <b>13'9"</b>	2.22 m <sup>3</sup> <b>2.90 yd<sup>3</sup></b>	2740 mm x 980 mm <b>9'0" x 3'3"</b>	890 mm <b>2'11"</b>	440 mm <b>1'5"</b>	395 mm <b>1'4"</b>	25°
D39PX-21 Power Angle Tilt Dozer	4200 mm <b>13'9"</b>	2.32 m <sup>3</sup> <b>3.00 yd<sup>3</sup></b>	3330 mm x 910 mm <b>10'11" x 3'0"</b>	890 mm <b>2'11"</b>	440 mm <b>1'5"</b>	480 mm <b>1'7"</b>	25°
D39PX-21 Power Angle Narrow Blade	4200 mm <b>13'9"</b>	2.08 m <sup>3</sup> <b>2.72 yd<sup>3</sup></b>	2980 mm x 910 mm <b>9'9" x 3'0"</b>	890 mm <b>2'11"</b>	440 mm <b>1'5"</b>	430 mm <b>1'5"</b>	22°



## STANDARD EQUIPMENT

- Air cleaner, double element with dust indicator
- Alternator, 35 ampere
- Back-up alarm
- Batteries, 60 Ah/2 x 12 V
- Blower cooling fan
- Cup holder
- Decelerator pedal
- Electronic instrument monitor panel
- Engine hood and gull-wing side covers
- Fenders
- Front pull hook
- High-mount footrests
- Intake pipe with precleaner
- Integrated double flange rollers
- Lighting system (includes 2 front, 1 rear)
- Locks, filler caps, and covers
- Muffler with curved exhaust pipe
- Palm Command Control System (PCCS)
- Radiator core protective grid
- Radiator guard door, bolt-on
- Radiator reserve tank
- Rear cover
- Rearview mirror
- ROPS mounting brackets
- Seat belt, 76 mm **3"** retractable
- Starting motor, 5.5 kW/24 V
- Suspension seat, reclining with headrest
- Track roller guard, end section
- Track shoe assembly
  - Sealed and lubricated track
    - 460 mm **18"** single grouser shoe (D39EX)
    - 635 mm **25"** single grouser shoe (D39PX)
- Underguards, oil pan and transmission
- Water separator



## OPTIONAL EQUIPMENT

- Air conditioner
- Cab accessories
  - Lunch box holder
  - Radio, AM/FM
- Hitch
- Hydraulics for ripper (D39EX)
- KOMTRAX™ function level 1
- Multi-Shank Ripper (D39EX)
  - Additional weight (including hydraulic control unit): 810 kg **1,790 lb**
  - Beam length: 1555 mm **5'1"**
  - Maximum digging depth: 510 mm **1'8"**
  - Maximum lift above ground: 350 mm **1'2"**
- Open ROPS heater
- ROPS/FOPS Level 2
  - Additional weight\*, 650 kg **1,430 lb**
  - All-weather, enclosed pressurized cab
  - Dimensions
    - Length: 1575 mm **5'2"**
    - Width: 1255 mm **4'1"**
    - Height: 1625 mm **5'4"**
    - Height from floor to ceiling: 1515 mm **5'0"**
- \*Including weight of air conditioner
- ROPS canopy
  - Additional weight, 310 kg **680 lb**
  - Roof dimensions
    - Length: 1575 mm **5'2"**
    - Width: 1255 mm **4'1"**
    - Height from operator compartment floor: 1575 mm **5'2"**
- Suspension seat
  - Reclining with fabric material and headrest (cab only)
- Sweeps and screens
- Track guard, full length, segmented
- Track shoe assembly
  - Sealed and lubricated track
    - 460 mm **18"** single grouser shoe with AR link (D39EX)
    - 510 mm **20"** single grouser shoe (D39EX)
    - 510 mm **20"** single grouser shoe with AR link (D39EX)
    - 700 mm **28"** swamp grouser shoe (D39PX)
    - 700 mm **28"** single grouser shoe (D39PX)
    - 635 mm **25"** single grouser shoe with AR link (D39PX)
- Vandalism protection cover for instrument panel
- Winch, mechanical

ROPS canopy or ROPS cab must be ordered for all machines.

**KOMATSU**®

